

PIEZO TRANSDUCER (Wire Type)

External Circuitry Type

Shape

KPE-110



RoHS Compliant Available (eg.KPEG110)

Model Number	KPE-110
Rated Voltage (Vp-p)	Max. 30
Current Consumption (mA)	Max. 12@10Vp-p,Square Wave,4.1KHz
Sound Pressure Level (dB)	Min. 90dB@10cm@10Vp-p,Square Wave,4.1KHz
Electrostatic Capacity(pF)	25,000±30%@1KHz@1V
Operating Temperature (°C)	-30 ~ +85
Storage Temperature (°C)	-40 ~ +95
Weight (Gram)	2.2
Material	ABS UL-94 1/16" HB High Heat (Black)

Dimension

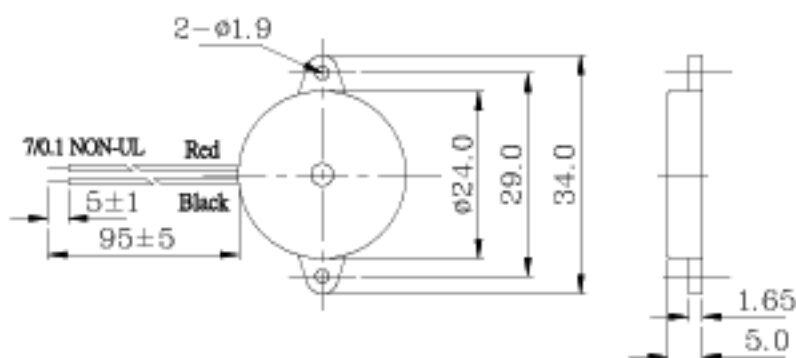

Tol : ±0.5 Unit : mm

Characteristic

