

PIEZO TRANSDUCER (Pin Type)

External Circuitry Type

Shape

KPE-112



RoHS Compliant Available (eg.KPEG112)

Model Number	KPE-112
Rated Voltage (Vp-p)	Max. 30
Current Consumption (mA)	Max. 11@10Vp-p,Square Wave,4.0KHz
Sound Pressure Level (dB)	Min. 92dB@10cm@10Vp-p,Square Wave,4.0KHz
Electrostatic Capacity (pF)	25,000±30%@1KHz@1V
Operating Temperature (°C)	-30 ~ +85
Storage Temperature (°C)	-40 ~ +95
Weight (Gram)	2.5
Material	ABS UL-94 1/16" HB High Heat (Black)

Dimension

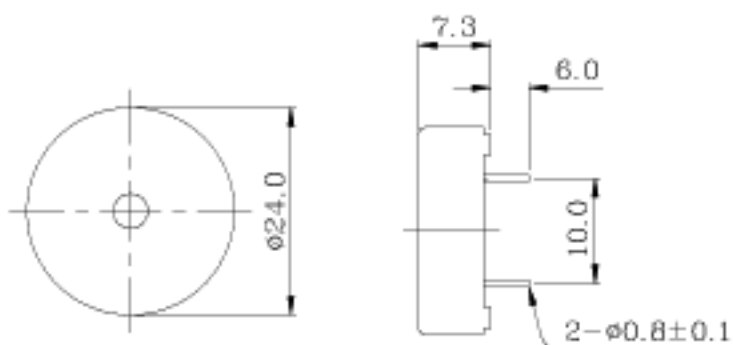

Tol : ±0.5 Unit : mm

Characteristic

